

## FSAM50SM60A

### SPM™ (Smart Power Module)

#### General Description

FSAM50SM60A is an advanced smart power module (SPM) that Fairchild has newly developed and designed to provide very compact and low cost, yet high performance ac motor drives mainly targeting medium speed low-power inverter-driven application like air conditioners. It combines optimized circuit protection and drive matched to low-loss IGBTs. Highly effective short-circuit current detection/protection is realized through the use of advanced current sensing IGBT chips that allow continuous monitoring of the IGBTs current. System reliability is further enhanced by the built-in over-temperature and integrated under-voltage lock-out protection. The high speed built-in HVIC provides opto-coupler-less IGBT gate driving capability that further reduce the overall size of the inverter system design. In addition the incorporated HVIC facilitates the use of single-supply drive topology enabling the FSAM50SM60A to be driven by only one drive supply voltage without negative bias. Inverter current sensing application can be achieved due to the devided nagative dc terminals.

#### Features

- UL Certified No. E209204
- 600V-50A 3-phase IGBT inverter bridge including control ICs for gate driving and protection
- Divided negative dc-link terminals for inverter current sensing applications
- Single-grounded power supply due to built-in HVIC
- Typical switching frequency of 5kHz
- Built-in thermistor for over-temperature monitoring
- Isolation rating of 2500Vrms/min.
- Very low leakage current due to using DBC (Direct Bonded Copper) substrate
- Adjustable current protection level by varying series resistor value with sense-IGBTs

#### Applications

- AC 100V ~ 253V three-phase inverter drive for small power ac motor drives
- Home appliances applications like air conditioners drive system

#### External View

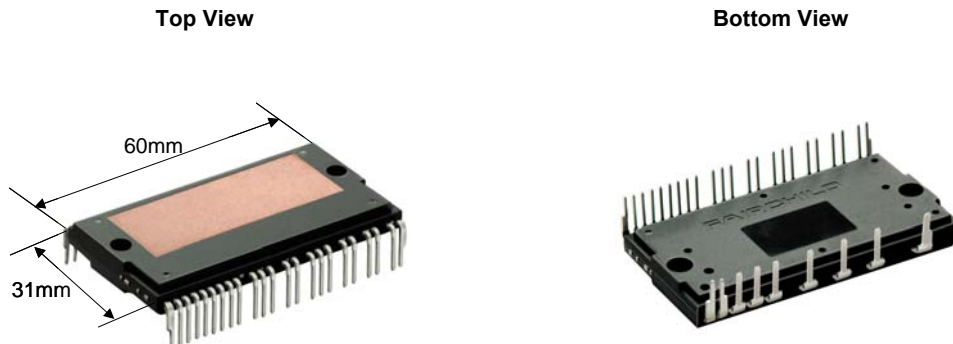

Fig. 1.

## Integrated Power Functions

- 600V-50A IGBT inverter for three-phase DC/AC power conversion (Please refer to Fig. 3)

## Integrated Drive, Protection and System Control Functions

- For inverter high-side IGBTs: Gate drive circuit, High voltage isolated high-speed level shifting  
Control circuit under-voltage (UV) protection  
Note) Available bootstrap circuit example is given in Figs. 13 and 14.
- For inverter low-side IGBTs: Gate drive circuit, Short circuit protection (SC)  
Control supply circuit under-voltage (UV) protection
- Temperature Monitoring: System over-temperature monitoring using built-in thermistor  
Note) Available temperature monitoring circuit is given in Fig. 14.
- Fault signaling: Corresponding to a SC fault (Low-side IGBTs) or a UV fault (Low-side control supply circuit)
- Input interface: 5V CMOS/LSTTL compatible, Schmitt trigger input

## Pin Configuration

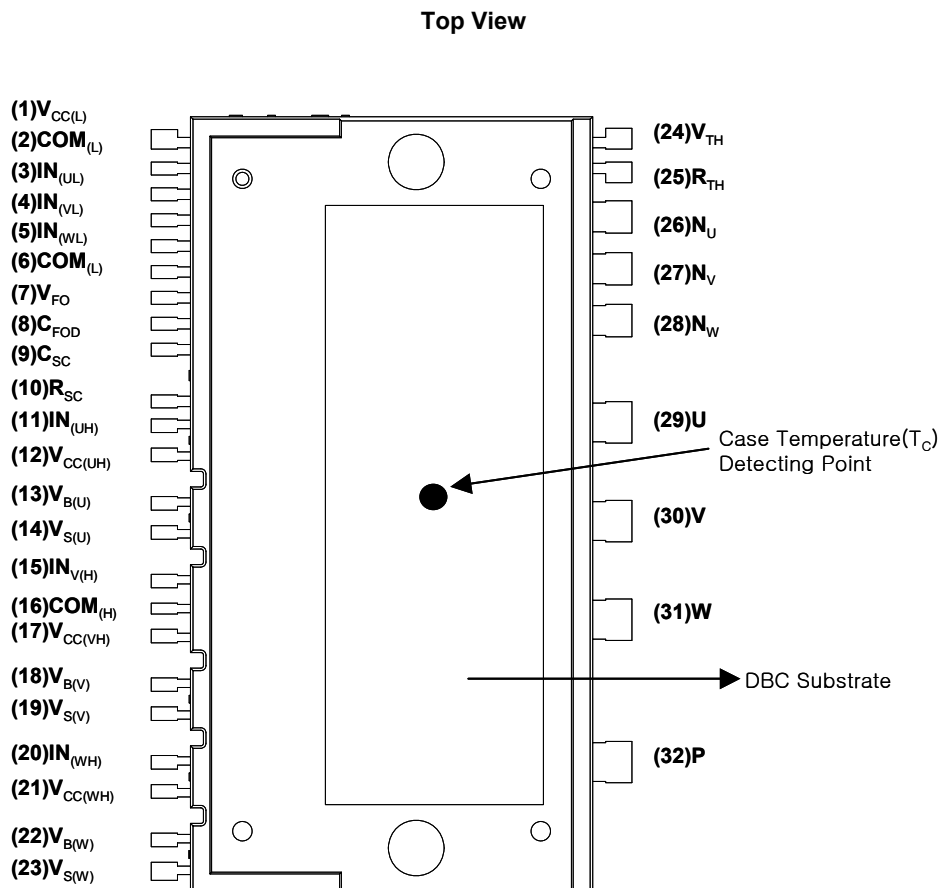
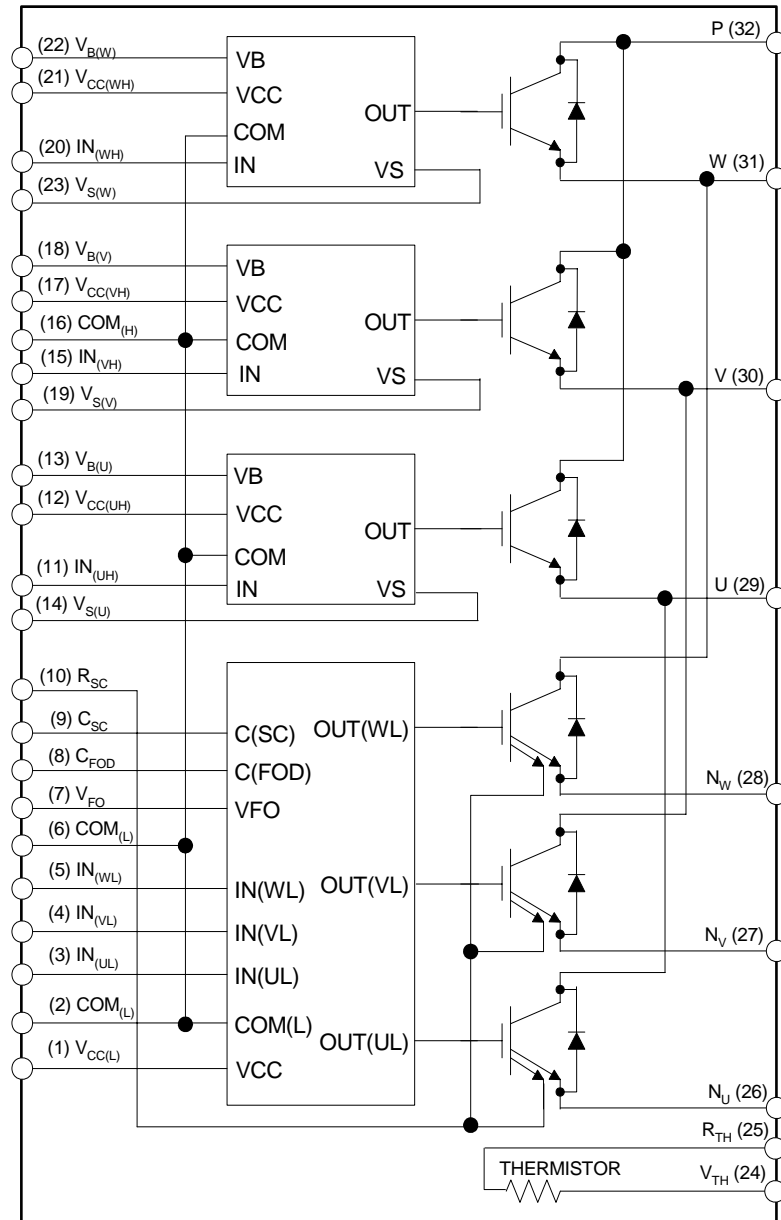

Fig. 2.

## Pin Descriptions

Pin Number	Pin Name	Pin Description
1	$V_{CC(L)}$	Low-side Common Bias Voltage for IC and IGBTs Driving
2	$COM_{(L)}$	Low-side Common Supply Ground
3	$IN_{(UL)}$	Signal Input Terminal for Low-side U Phase
4	$IN_{(VL)}$	Signal Input Terminal for Low-side V Phase
5	$IN_{(WL)}$	Signal Input Terminal for Low-side W Phase
6	$COM_{(L)}$	Low-side Common Supply Ground
7	$V_{FO}$	Fault Output
8	$C_{FOD}$	Capacitor for Fault Output Duration Time Selection
9	$C_{SC}$	Capacitor (Low-pass Filter) for Short-Circuit Current Detection Input
10	$R_{SC}$	Resistor for Short-circuit Current Detection
11	$IN_{(UH)}$	Signal Input for High-side U Phase
12	$V_{CC(UH)}$	High-side Bias Voltage for U Phase IC
13	$V_{B(U)}$	High-side Bias Voltage for U Phase IGBT Driving
14	$V_{S(U)}$	High-side Bias Voltage Ground for U Phase IGBT Driving
15	$IN_{(VH)}$	Signal Input for High-side V Phase
16	$COM_{(H)}$	High-side Common Supply Ground
17	$V_{CC(VH)}$	High-side Bias Voltage for V Phase IC
18	$V_{B(V)}$	High-side Bias Voltage for V Phase IGBT Driving
19	$V_{S(V)}$	High-side Bias Voltage Ground for V Phase IGBT Driving
20	$IN_{(WH)}$	Signal Input for High-side W Phase
21	$V_{CC(WH)}$	High-side Bias Voltage for W Phase IC
22	$V_{B(W)}$	High-side Bias Voltage for W Phase IGBT Driving
23	$V_{S(W)}$	High-side Bias Voltage Ground for W Phase IGBT Driving
24	$V_{TH}$	Thermistor Bias Voltage
25	$R_{TH}$	Series Resistor for the Use of Thermistor (Temperature Detection)
26	$N_U$	Negative DC-Link Input Terminal for U Phase
27	$N_V$	Negative DC-Link Input Terminal for V Phase
28	$N_W$	Negative DC-Link Input Terminal for W Phase
29	U	Output for U Phase
30	V	Output for V Phase
31	W	Output for W Phase
32	P	Positive DC-Link Input

Internal Equivalent Circuit and Input/Output Pins



Note

1. Inverter low-side is composed of three sense-IGBTs including freewheeling diodes for each IGBT and one control IC which has gate driving, current sensing and protection functions.
2. Inverter power side is composed of four inverter dc-link input pins and three inverter output pins.
3. Inverter high-side is composed of three normal-IGBTs including freewheeling diodes and three drive ICs for each IGBT.

Fig. 3.

**Absolute Maximum Ratings** ( $T_J = 25^\circ\text{C}$ , Unless Otherwise Specified)**Inverter Part**

Item	Symbol	Condition	Rating	Unit
Supply Voltage	$V_{DC}$	Applied to DC - Link	450	V
Supply Voltage (Surge)	$V_{PN(\text{Surge})}$	Applied between P- N	500	V
Collector-emitter Voltage	$V_{CES}$		600	V
Each IGBT Collector Current	$\pm I_C$	$T_C = 25^\circ\text{C}$	50	A
Each IGBT Collector Current	$\pm I_C$	$T_C = 100^\circ\text{C}$	25	A
Each IGBT Collector Current (Peak)	$\pm I_{CP}$	$T_C = 25^\circ\text{C}$ , Under 1ms pulse width	100	A
Collector Dissipation	$P_C$	$T_C = 25^\circ\text{C}$ per One Chip	100	W
Operating Junction Temperature	$T_J$	(Note 1)	-20 ~ 125	$^\circ\text{C}$

**Note**

1. It would be recommended that the average junction temperature should be limited to  $T_J \leq 125^\circ\text{C}$  ( $@T_C \leq 100^\circ\text{C}$ ) in order to guarantee safe operation.

**Control Part**

Item	Symbol	Condition	Rating	Unit
Control Supply Voltage	$V_{CC}$	Applied between $V_{CC(UH)}$ , $V_{CC(VH)}$ , $V_{CC(WH)}$ - $COM_{(H)}$ , $V_{CC(L)}$ - $COM_{(L)}$	20	V
High-side Control Bias Voltage	$V_{BS}$	Applied between $V_{B(U)}$ - $V_{S(U)}$ , $V_{B(V)}$ - $V_{S(V)}$ , $V_{B(W)}$ - $V_{S(W)}$	20	V
Input Signal Voltage	$V_{IN}$	Applied between $IN_{(UH)}$ , $IN_{(VH)}$ , $IN_{(WH)}$ - $COM_{(H)}$ $IN_{(UL)}$ , $IN_{(VL)}$ , $IN_{(WL)}$ - $COM_{(L)}$	-0.3 ~ $V_{CC}+0.3$	V
Fault Output Supply Voltage	$V_{FO}$	Applied between $V_{FO}$ - $COM_{(L)}$	-0.3 ~ $V_{CC}+0.3$	V
Fault Output Current	$I_{FO}$	Sink Current at $V_{FO}$ Pin	5	mA
Current Sensing Input Voltage	$V_{SC}$	Applied between $C_{SC}$ - $COM_{(L)}$	-0.3 ~ $V_{CC}+0.3$	V

**Total System**

Item	Symbol	Condition	Rating	Unit
Self Protection Supply Voltage Limit (Short Circuit Protection Capability)	$V_{PN(\text{PROT})}$	Applied to DC - Link, $V_{CC} = V_{BS} = 13.5 \sim 16.5\text{V}$ $T_J = 125^\circ\text{C}$ , Non-repetitive, less than $5\mu\text{s}$	400	V
Module Case Operation Temperature	$T_C$	Note Fig. 2	-20 ~ 100	$^\circ\text{C}$
Storage Temperature	$T_{STG}$		-20 ~ 125	$^\circ\text{C}$
Isolation Voltage	$V_{ISO}$	60Hz, Sinusoidal, AC 1 minute, Connection Pins to Heat-sink Plate	2500	$V_{rms}$

## Absolute Maximum Ratings

### Thermal Resistance

Item	Symbol	Condition	Min.	Typ.	Max.	Unit
Junction to Case Thermal Resistance	$R_{th(j-c)Q}$	Inverter IGBT part (per 1/6 module)	-	-	1.0	°C/W
	$R_{th(j-c)F}$	Inverter FWDi part (per 1/6 module)	-	-	1.5	°C/W
Contact Thermal Resistance	$R_{th(c-f)}$	Ceramic Substrate (per 1 Module) Thermal Grease Applied (Note 3)	-	-	0.06	°C/W

**Note**

- For the measurement point of case temperature( $T_C$ ), please refer to Fig. 2.
- The thickness of thermal grease should not be more than 100um.

### Package Marking and Ordering Information

Device Marking	Device	Package	Real Size	Tape Width	Quantity
FSAM50SM60A	FSAM50SM60A	SPM32-CA	-	-	8

## Electrical Characteristics

### Inverter Part ( $T_J = 25^\circ\text{C}$ , Unless Otherwise Specified)

Item	Symbol	Condition	Min.	Typ.	Max.	Unit
Collector - emitter Saturation Voltage	$V_{CE(SAT)}$	$V_{CC} = V_{BS} = 15V$ $V_{IN} = 0V$ $I_C = 50A, T_J = 25^\circ\text{C}$	-	-	2.4	V
FWDi Forward Voltage	$V_{FM}$	$V_{IN} = 5V$ $I_C = 50A, T_J = 25^\circ\text{C}$	-	-	2.1	V
Switching Times	$t_{ON}$	$V_{PN} = 300V, V_{CC} = V_{BS} = 15V$ $I_C = 50A, T_J = 25^\circ\text{C}$ $V_{IN} = 5V \leftrightarrow 0V$ , Inductive Load (High-Low Side) (Note 4)	-	0.69	-	$\mu\text{s}$
	$t_{C(ON)}$		-	0.32	-	$\mu\text{s}$
	$t_{OFF}$		-	1.32	-	$\mu\text{s}$
	$t_{C(OFF)}$		-	0.46	-	$\mu\text{s}$
	$t_{rr}$		-	0.10	-	$\mu\text{s}$
Collector - emitter Leakage Current	$I_{CES}$	$V_{CE} = V_{CES}, T_J = 25^\circ\text{C}$	-	-	250	$\mu\text{A}$

**Note**

- $t_{ON}$  and  $t_{OFF}$  include the propagation delay time of the internal drive IC.  $t_{C(ON)}$  and  $t_{C(OFF)}$  are the switching time of IGBT itself under the given gate driving condition internally. For the detailed information, please see Fig. 4.

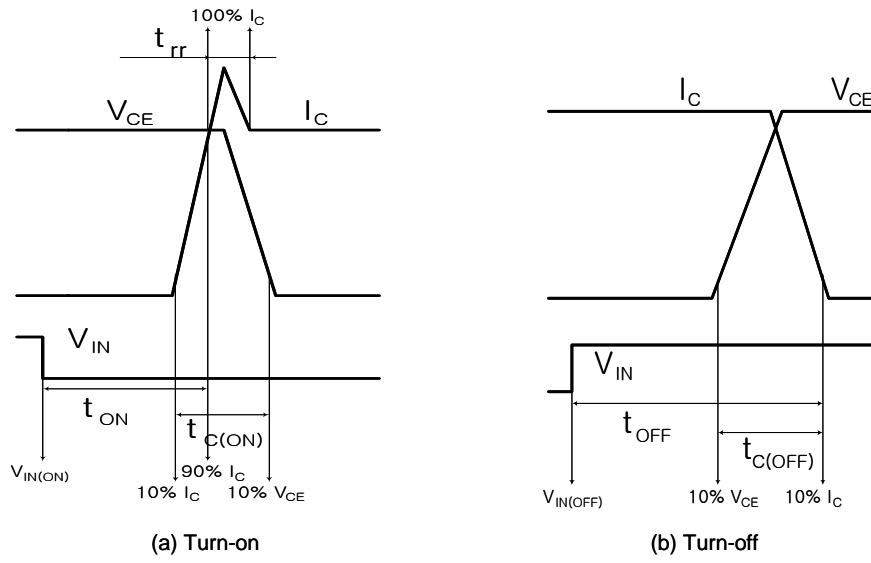

Fig. 4. Switching Time Definition

## Electrical Characteristics (T<sub>J</sub> = 25°C, Unless Otherwise Specified)

### Control Part

Item	Symbol	Condition	Min.	Typ.	Max.	Unit		
Quiescent V <sub>CC</sub> Supply Current	I <sub>QCCL</sub>	V <sub>CC</sub> = 15V IN <sub>(UL, VL, WL)</sub> = 5V	V <sub>CC(L)</sub> - COM <sub>(L)</sub>	-	-	26	mA	
	I <sub>QCCH</sub>	V <sub>CC</sub> = 15V IN <sub>(UH, VH, WH)</sub> = 5V	V <sub>CC(UH)</sub> , V <sub>CC(VH)</sub> , V <sub>CC(WH)</sub> - COM <sub>(H)</sub>	-	-	130	uA	
Quiescent V <sub>BS</sub> Supply Current	I <sub>QBS</sub>	V <sub>BS</sub> = 15V IN <sub>(UH, VH, WH)</sub> = 5V	V <sub>B(U)</sub> - V <sub>S(U)</sub> , V <sub>B(V)</sub> - V <sub>S(V)</sub> , V <sub>B(W)</sub> - V <sub>S(W)</sub>	-	-	420	uA	
Fault Output Voltage	V <sub>FOH</sub>	V <sub>SC</sub> = 0V, V <sub>FO</sub> Circuit: 4.7kΩ to 5V Pull-up	4.5	-	-	V		
	V <sub>FOL</sub>	V <sub>SC</sub> = 1V, V <sub>FO</sub> Circuit: 4.7kΩ to 5V Pull-up	-	-	1.1	V		
Short-Circuit Trip Level	V <sub>SC(ref)</sub>	V <sub>CC</sub> = 15V (Note 5)	0.45	0.51	0.56	V		
Sensing Voltage of IGBT Current	V <sub>SEN</sub>	R <sub>SC</sub> = 40 Ω, R <sub>SU</sub> = R <sub>SV</sub> = R <sub>SW</sub> = 0 Ω and I <sub>C</sub> = 75A (Fig. 6)	0.45	0.51	0.56	V		
Supply Circuit Under-Voltage Protection	UV <sub>CCD</sub>	Detection Level	11.5	12	12.5	V		
	UV <sub>CCR</sub>	Reset Level	12	12.5	13	V		
	UV <sub>BSD</sub>	Detection Level	7.3	9.0	10.8	V		
	UV <sub>BSR</sub>	Reset Level	8.6	10.3	12	V		
Fault Output Pulse Width	t <sub>FOD</sub>	C <sub>FOD</sub> = 33nF (Note 6)	1.4	1.8	2.0	ms		
ON Threshold Voltage	V <sub>IN(ON)</sub>	High-Side	Applied between IN <sub>(UH)</sub> , IN <sub>(VH)</sub> , IN <sub>(WH)</sub> - COM <sub>(H)</sub>		-	-	0.8	V
OFF Threshold Voltage	V <sub>IN(OFF)</sub>		3.0	-	-	V		
ON Threshold Voltage	V <sub>IN(ON)</sub>	Low-Side	Applied between IN <sub>(UL)</sub> , IN <sub>(VL)</sub> , IN <sub>(WL)</sub> - COM <sub>(L)</sub>		-	-	0.8	V
OFF Threshold Voltage	V <sub>IN(OFF)</sub>		3.0	-	-	V		
Resistance of Thermistor	R <sub>TH</sub>	@ T <sub>TH</sub> = 25°C (Note Fig. 6) (Note 7)	-	50	-	kΩ		
		@ T <sub>TH</sub> = 100°C (Note Fig. 6) (Note 7)	-	3.0	-	kΩ		

**Note:**

- Short-circuit current protection is functioning only at the low-sides. It would be recommended that the value of the external sensing resistor (R<sub>SC</sub>) should be selected around 40 Ω in order to make the SC trip-level of about 75A at the shunt resistors (R<sub>SU</sub>, R<sub>SV</sub>, R<sub>SW</sub>) of 0Ω. For the detailed information about the relationship between the external sensing resistor (R<sub>SC</sub>) and the shunt resistors (R<sub>SU</sub>, R<sub>SV</sub>, R<sub>SW</sub>), please see Fig. 6.
- The fault-out pulse width t<sub>FOD</sub> depends on the capacitance value of C<sub>FOD</sub> according to the following approximate equation : C<sub>FOD</sub> = 18.3 x 10<sup>-6</sup> x t<sub>FOD</sub>[F]
- T<sub>TH</sub> is the temperature of thermistor itself. To know case temperature (T<sub>C</sub>), please make the experiment considering your application.

### Recommended Operating Conditions

Item	Symbol	Condition	Values			Unit
			Min.	Typ.	Max.	
Supply Voltage	V <sub>PN</sub>	Applied between P - N <sub>U</sub> , N <sub>V</sub> , N <sub>W</sub>	-	300	400	V
Control Supply Voltage	V <sub>CC</sub>	Applied between V <sub>CC(UH)</sub> , V <sub>CC(VH)</sub> , V <sub>CC(WH)</sub> - COM <sub>(H)</sub> , V <sub>CC(L)</sub> - COM <sub>(L)</sub>	13.5	15	16.5	V
High-side Bias Voltage	V <sub>BS</sub>	Applied between V <sub>B(U)</sub> - V <sub>S(U)</sub> , V <sub>B(V)</sub> - V <sub>S(V)</sub> , V <sub>B(W)</sub> - V <sub>S(W)</sub>	13.0	15	18.5	V
Blanking Time for Preventing Arm-short	t <sub>dead</sub>	For Each Input Signal	3.5	-	-	us
PWM Input Signal	f <sub>PWM</sub>	T <sub>C</sub> ≤ 100°C, T <sub>J</sub> ≤ 125°C	-	5	-	kHz
Minimum Input Pulse Width	PW <sub>IN(OFF)</sub>	200 ≤ V <sub>PN</sub> ≤ 400V, 13.5 ≤ V <sub>CC</sub> ≤ 16.5V, 13.0 ≤ V <sub>BS</sub> ≤ 18.5V, 0 ≤ I <sub>C</sub> ≤ 100A, -20 ≤ T <sub>J</sub> ≤ 125°C V <sub>IN</sub> = 5V ↔ 0V, Inductive Load (Note 8)	3	-	-	us
Input ON Threshold Voltage	V <sub>IN(ON)</sub>	Applied between IN <sub>(UH)</sub> , IN <sub>(VH)</sub> , IN <sub>(WH)</sub> - COM <sub>(H)</sub> , IN <sub>(UL)</sub> , IN <sub>(VL)</sub> , IN <sub>(WL)</sub> - COM <sub>(L)</sub>	0 ~ 0.65			V
Input OFF Threshold Voltage	V <sub>IN(OFF)</sub>	Applied between IN <sub>(UH)</sub> , IN <sub>(VH)</sub> , IN <sub>(WH)</sub> - COM <sub>(H)</sub> , IN <sub>(UL)</sub> , IN <sub>(VL)</sub> , IN <sub>(WL)</sub> - COM <sub>(L)</sub>	4 ~ 5.5			V

**Note:**

- SPM might not make response if the PW<sub>IN(OFF)</sub> is less than the recommended minimum value.



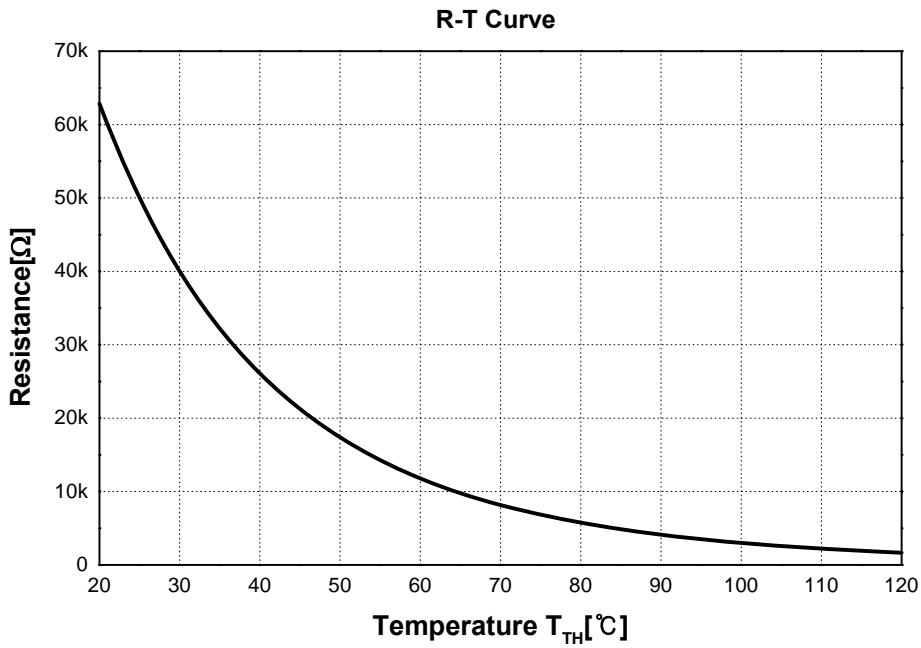

Fig. 5. R-T Curve of The Built-in Thermistor

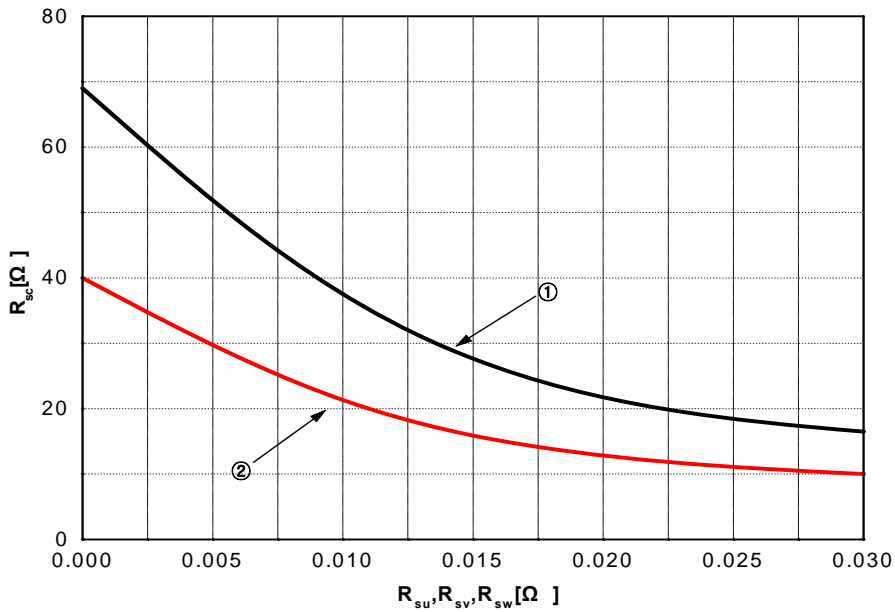
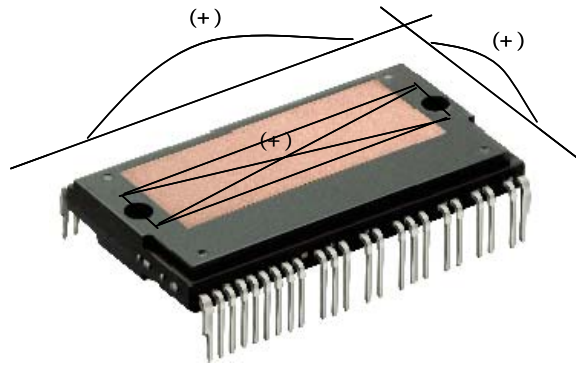

Fig. 6.  $R_{SC}$  Variation by change of Shunt Resistors ( $R_{SU}, R_{SV}, R_{SW}$ ) for Short-Circuit Protection  
 ① @ Current Trip Level  $\approx$  50A,  
 ② @ Current Trip Level  $\approx$  75A

**Mechanical Characteristics and Ratings**

Item	Condition	Limits			Units	
		Min.	Typ.	Max.		
Mounting Torque	Mounting Screw: M4 (Note 9 and 10)	Recommended 10Kg*cm	8	10	12	Kg*cm
		Recommended 0.98N*m	0.78	0.98	1.17	N*m
DBC Flatness	Note Fig.7	0	-	+120	μm	
Weight		-	32	-	g	



**Fig. 7. Flatness Measurement Position of The DBC Substrate**

**Note:**

- 9. Do not make over torque or mounting screws. Much mounting torque may cause ceramic cracks and bolts and Al heat-fin destruction.
- 10. Avoid one side tightening stress. Fig.8 shows the recommended torque order for mounting screws. Uneven mounting can cause the SPM ceramic substrate to be damaged.

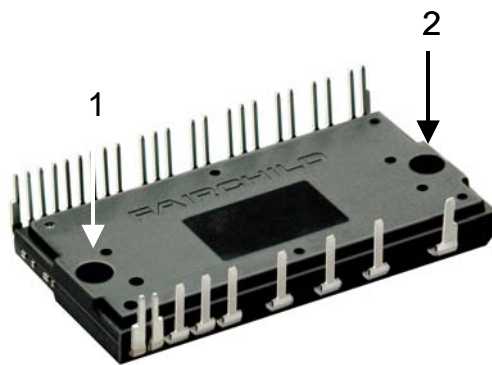

**Fig. 8. Mounting Screws Torque Order (1 → 2)**

**Time Charts of SPMs Protective Function**

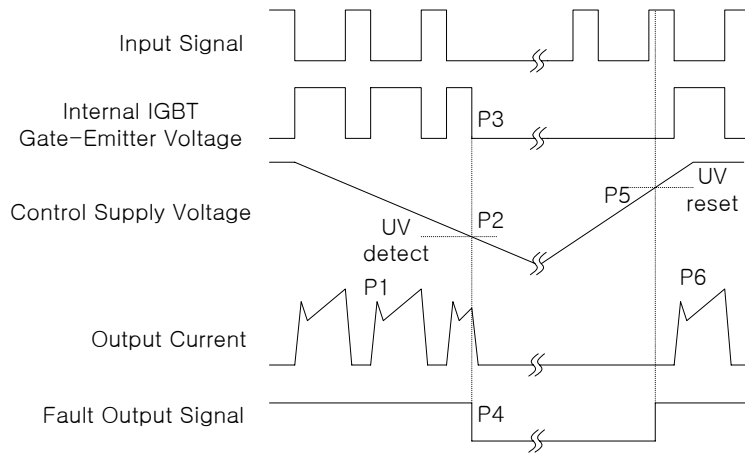

- P1 : Normal operation - IGBT ON and conducting current
- P2 : Under voltage detection
- P3 : IGBT gate interrupt
- P4 : Fault signal generation
- P5 : Under voltage reset
- P6 : Normal operation - IGBT ON and conducting current

**Fig. 9. Under-Voltage Protection (Low-side)**

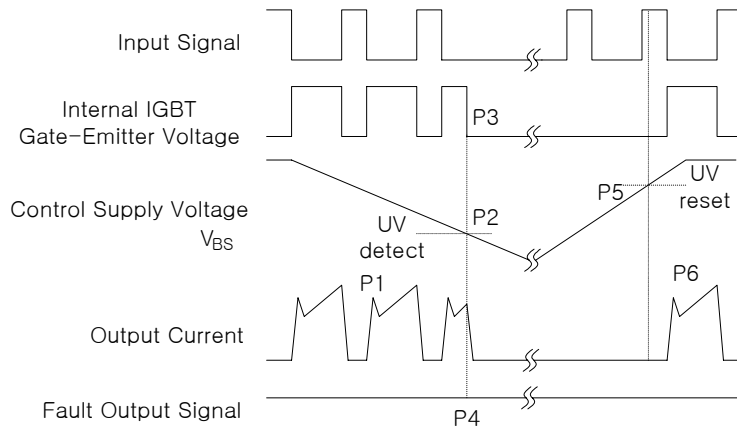

- P1 : Normal operation - IGBT ON and conducting current
- P2 : Under voltage detection
- P3 : IGBT gate interrupt
- P4 : No fault signal
- P5 : Under voltage reset
- P6 : Normal operation - IGBT ON and conducting current

**Fig. 10. Under-Voltage Protection (High-side)**

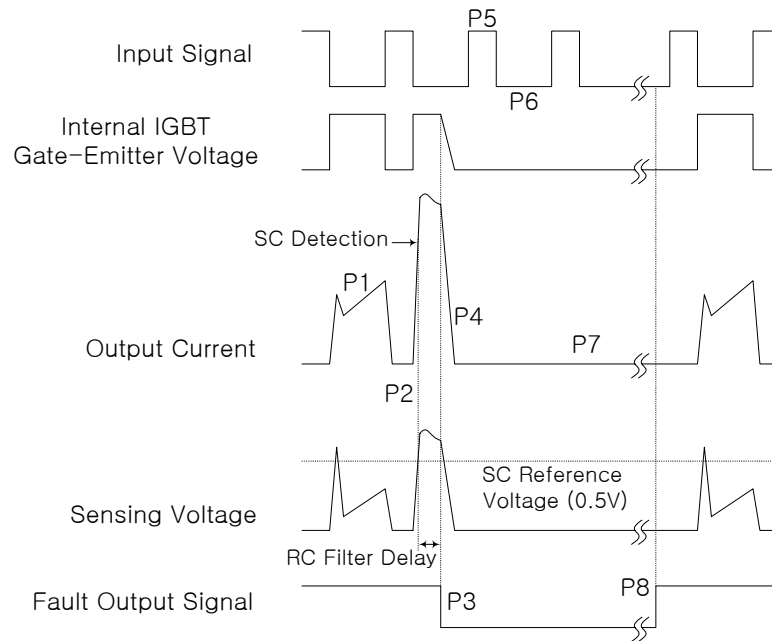

- P1 : Normal operation - IGBT ON and conducting currents
- P2 : Short-circuit current detection
- P3 : IGBT gate interrupt / Fault signal generation
- P4 : IGBT is slowly turned off
- P5 : IGBT OFF signal
- P6 : IGBT ON signal - but IGBT cannot be turned on during the fault-output activation
- P7 : IGBT OFF state
- P8 : Fault-output reset and normal operation start

**Fig. 11. Short-circuit Current Protection (Low-side Operation only)**

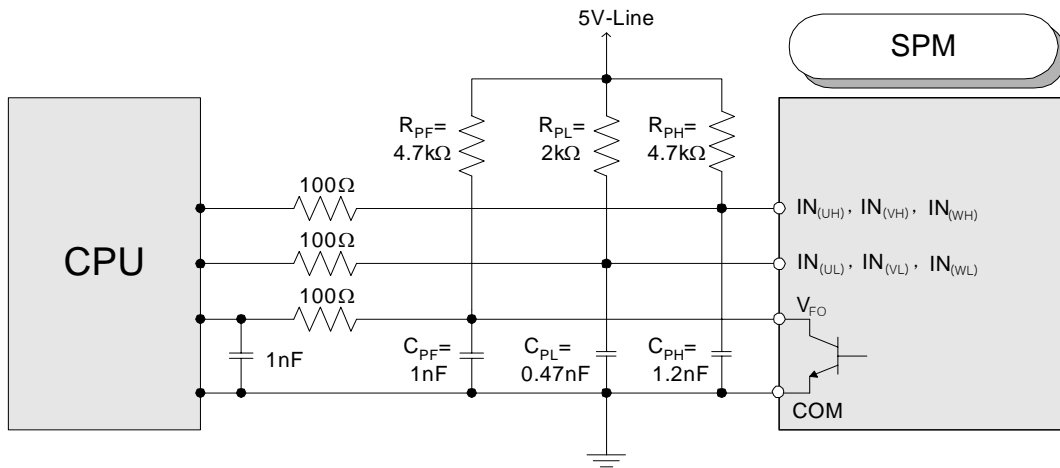

**Note:**

- 1) It would be recommended that by-pass capacitors for the gating input signals,  $IN_{(UL)}$ ,  $IN_{(VL)}$ ,  $IN_{(WL)}$ ,  $IN_{(UH)}$ ,  $IN_{(VH)}$  and  $IN_{(WH)}$  should be placed on the SPM pins and on the both sides of CPU and SPM for the fault output signal,  $V_{FO}$ , as close as possible.
- 2) The logic input is compatible with standard CMOS or LSTTL outputs.
- 3)  $R_{PL}C_{PL}/R_{PH}C_{PH}/R_{PF}C_{PF}$  coupling at each SPM input is recommended in order to prevent input/output signals' oscillation and it should be as close as possible to each of SPM pins.

**Fig. 12. Recommended CPU I/O Interface Circuit**

*These Values depend on PWM Control Algorithm*

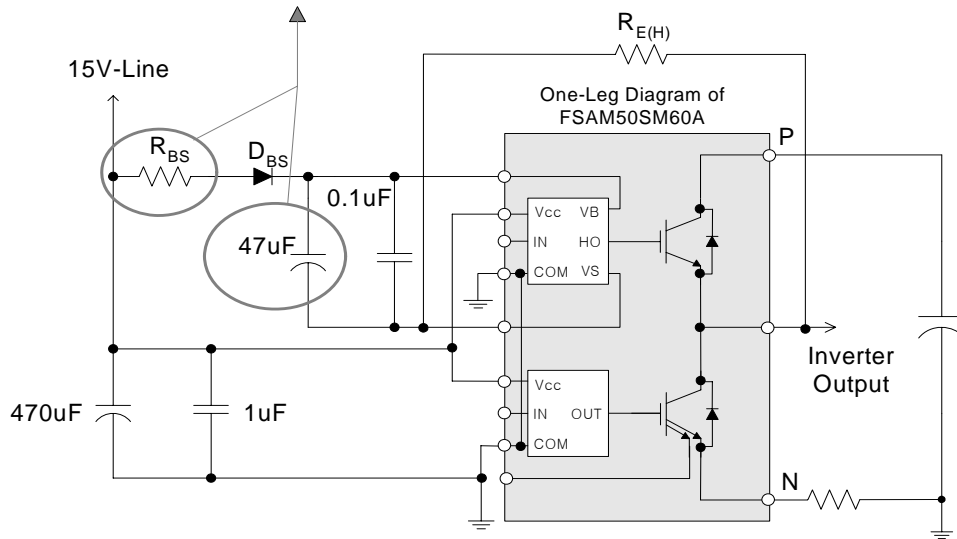

**Note:**

- 1) It would be recommended that the bootstrap diode,  $D_{BS}$ , has soft and fast recovery characteristics.
- 2) The bootstrap resistor ( $R_{BS}$ ) should be 3 times greater than  $R_{E(H)}$ . The recommended value of  $R_{E(H)}$  is 5.6Ω, but it can be increased up to 20Ω for a slower dv/dt of high-side.
- 3) The ceramic capacitor placed between  $V_{CC}$ -COM should be over 1μF and mounted as close to the pins of the SPM as possible.

**Fig. 13. Recommended Bootstrap Operation Circuit and Parameters**

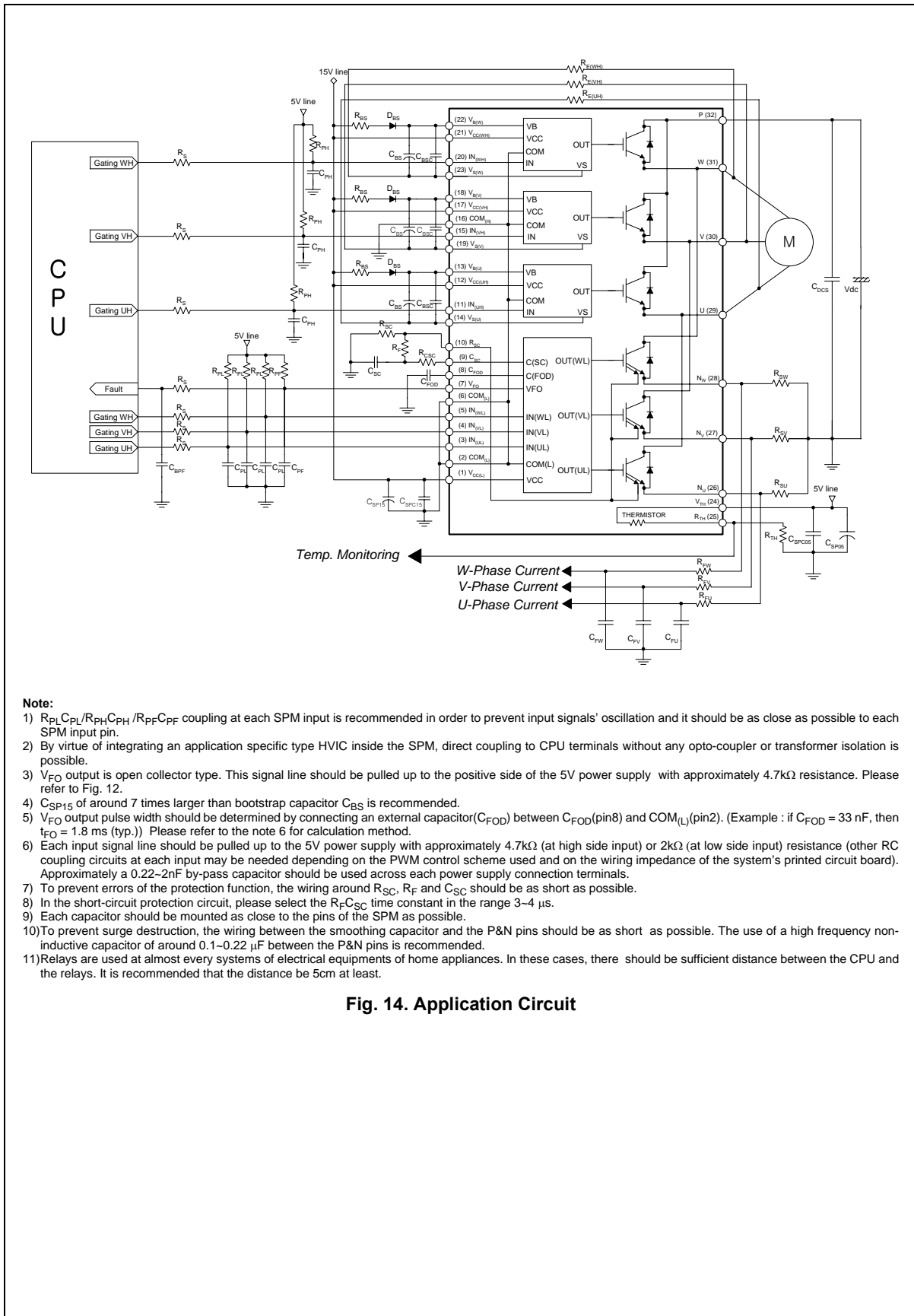

**Note:**

- 1)  $R_{PL}C_{PL}/R_{PH}C_{PH}/R_{PF}C_{PF}$  coupling at each SPM input is recommended in order to prevent input signals' oscillation and it should be as close as possible to each SPM input pin.
- 2) By virtue of integrating an application specific type HVIC inside the SPM, direct coupling to CPU terminals without any opto-coupler or transformer isolation is possible.
- 3)  $V_{FO}$  output is open collector type. This signal line should be pulled up to the positive side of the 5V power supply with approximately 4.7k $\Omega$  resistance. Please refer to Fig. 12.
- 4)  $C_{SP15}$  of around 7 times larger than bootstrap capacitor  $C_{BS}$  is recommended.
- 5)  $V_{FO}$  output pulse width should be determined by connecting an external capacitor ( $C_{FOD}$ ) between  $C_{FOD}$ (pin8) and  $COM_{(L)}$ (pin2). (Example : if  $C_{FOD} = 33$  nF, then  $t_{FO} = 1.8$  ms (typ.)) Please refer to the note 6 for calculation method.
- 6) Each input signal line should be pulled up to the 5V power supply with approximately 4.7k $\Omega$  (at high side input) or 2k $\Omega$  (at low side input) resistance (other RC coupling circuits at each input may be needed depending on the PWM control scheme used and on the wiring impedance of the system's printed circuit board). Approximately a 0.22-2nF by-pass capacitor should be used across each power supply connection terminals.
- 7) To prevent errors of the protection function, the wiring around  $R_{SC}$ ,  $R_F$  and  $C_{SC}$  should be as short as possible.
- 8) In the short-circuit protection circuit, please select the  $R_F C_{SC}$  time constant in the range 3-4  $\mu$ s.
- 9) Each capacitor should be mounted as close to the pins of the SPM as possible.
- 10) To prevent surge destruction, the wiring between the smoothing capacitor and the P&N pins should be as short as possible. The use of a high frequency non-inductive capacitor of around 0.1-0.22  $\mu$ F between the P&N pins is recommended.
- 11) Relays are used at almost every systems of electrical equipments of home appliances. In these cases, there should be sufficient distance between the CPU and the relays. It is recommended that the distance be 5cm at least.

**Fig. 14. Application Circuit**



## TRADEMARKS

The following are registered and unregistered trademarks Fairchild Semiconductor owns or is authorized to use and is not intended to be an exhaustive list of all such trademarks.

ACE <sup>x</sup> <sup>™</sup>	FACT Quiet Series <sup>™</sup>	OCX <sup>™</sup>	SILENT SWITCHER <sup>®</sup>	UniFET <sup>™</sup>
ActiveArray <sup>™</sup>	GlobalOptoisolator <sup>™</sup>	OCXPro <sup>™</sup>	SMART START <sup>™</sup>	UltraFET <sup>®</sup>
Bottomless <sup>™</sup>	GTO <sup>™</sup>	OPTOLOGIC <sup>®</sup>	SPM <sup>™</sup>	VCX <sup>™</sup>
Build it Now <sup>™</sup>	HiSeC <sup>™</sup>	OPTOPLANAR <sup>™</sup>	Stealth <sup>™</sup>	Wire <sup>™</sup>
CoolFET <sup>™</sup>	I <sup>2</sup> C <sup>™</sup>	PACMAN <sup>™</sup>	SuperFET <sup>™</sup>	
CROSSVOLT <sup>™</sup>	<i>i-Lo</i> <sup>™</sup>	POP <sup>™</sup>	SuperSOT <sup>™</sup> -3	
DOMET <sup>™</sup>	ImpliedDisconnect <sup>™</sup>	Power247 <sup>™</sup>	SuperSOT <sup>™</sup> -6	
EcoSPARK <sup>™</sup>	IntelliMAX <sup>™</sup>	PowerEdge <sup>™</sup>	SuperSOT <sup>™</sup> -8	
E <sup>2</sup> CMOS <sup>™</sup>	ISOPLANAR <sup>™</sup>	PowerSaver <sup>™</sup>	SyncFET <sup>™</sup>	
EnSigna <sup>™</sup>	LittleFET <sup>™</sup>	PowerTrench <sup>®</sup>	TCM <sup>™</sup>	
FACT <sup>™</sup>	MICROCOUPLER <sup>™</sup>	QFET <sup>®</sup>	TinyBoost <sup>™</sup>	
FAST <sup>®</sup>	MicroFET <sup>™</sup>	QS <sup>™</sup>	TinyBuck <sup>™</sup>	
FAST <sub>r</sub> <sup>™</sup>	MicroPak <sup>™</sup>	QT Optoelectronics <sup>™</sup>	TinyPWM <sup>™</sup>	
FPS <sup>™</sup>	MICROWIRE <sup>™</sup>	Quiet Series <sup>™</sup>	TinyPower <sup>™</sup>	
FRFET <sup>™</sup>	MSX <sup>™</sup>	RapidConfigure <sup>™</sup>	TinyLogic <sup>®</sup>	
	MSXPro <sup>™</sup>	RapidConnect <sup>™</sup>	TINYOPTO <sup>™</sup>	
Across the board. Around the world. <sup>™</sup>		μSerDes <sup>™</sup>	TruTranslation <sup>™</sup>	
The Power Franchise <sup>®</sup>		ScalarPump <sup>™</sup>	UHC <sup>™</sup>	
Programmable Active Droop <sup>™</sup>				

## DISCLAIMER

FAIRCHILD SEMICONDUCTOR RESERVES THE RIGHT TO MAKE CHANGES WITHOUT FURTHER NOTICE TO ANY PRODUCTS HEREIN TO IMPROVE RELIABILITY, FUNCTION, OR DESIGN. FAIRCHILD DOES NOT ASSUME ANY LIABILITY ARISING OUT OF THE APPLICATION OR USE OF ANY PRODUCT OR CIRCUIT DESCRIBED HEREIN; NEITHER DOES IT CONVEY ANY LICENSE UNDER ITS PATENT RIGHTS, NOR THE RIGHTS OF OTHERS. THESE SPECIFICATIONS DO NOT EXPAND THE TERMS OF FAIRCHILD'S WORLDWIDE TERMS AND CONDITIONS, SPECIFICALLY THE WARRANTY THEREIN, WHICH COVERS THESE PRODUCTS.

## LIFE SUPPORT POLICY

FAIRCHILD'S PRODUCTS ARE NOT AUTHORIZED FOR USE AS CRITICAL COMPONENTS IN LIFE SUPPORT DEVICES OR SYSTEMS WITHOUT THE EXPRESS WRITTEN APPROVAL OF FAIRCHILD SEMICONDUCTOR CORPORATION.

As used herein:

- Life support devices or systems are devices or systems which, (a) are intended for surgical implant into the body, or (b) support or sustain life, or (c) whose failure to perform when properly used in accordance with instructions for use provided in the labeling, can be reasonably expected to result in significant injury to the user.
- A critical component is any component of a life support device or system whose failure to perform can be reasonably expected to cause the failure of the life support device or system, or to affect its safety or effectiveness.

## PRODUCT STATUS DEFINITIONS

### Definition of Terms

Datasheet Identification	Product Status	Definition
Advance Information	Formative or In Design	This datasheet contains the design specifications for product development. Specifications may change in any manner without notice.
Preliminary	First Production	This datasheet contains preliminary data, and supplementary data will be published at a later date. Fairchild Semiconductor reserves the right to make changes at any time without notice to improve design.
No Identification Needed	Full Production	This datasheet contains final specifications. Fairchild Semiconductor reserves the right to make changes at any time without notice to improve design.
Obsolete	Not In Production	This datasheet contains specifications on a product that has been discontinued by Fairchild semiconductor. The datasheet is printed for reference information only.